



# Dispositifs Médicaux de Mesure des signaux physiologiques

*Dr Amalric Montalibet*

*Pr. Norbert Noury*



Université Claude Bernard



Lyon 1



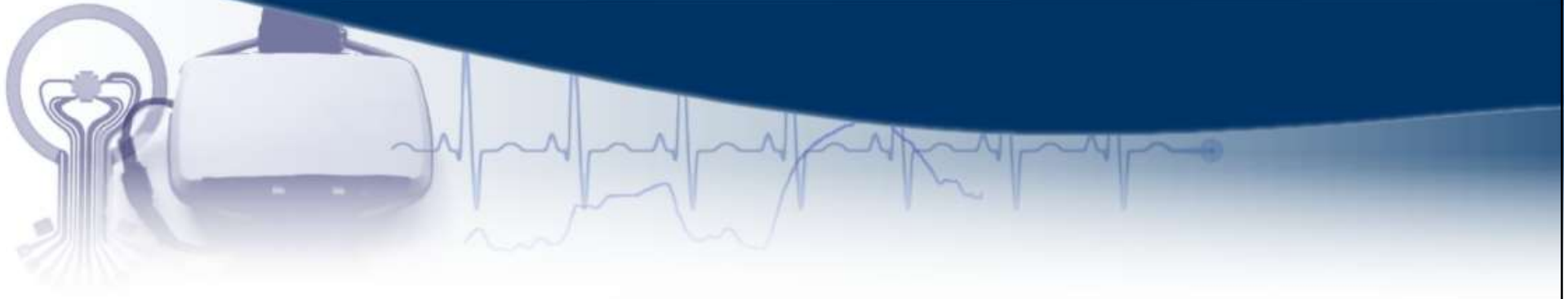

# 3 Mesure des biopotentiels

## *3E- Impédancemétrie*

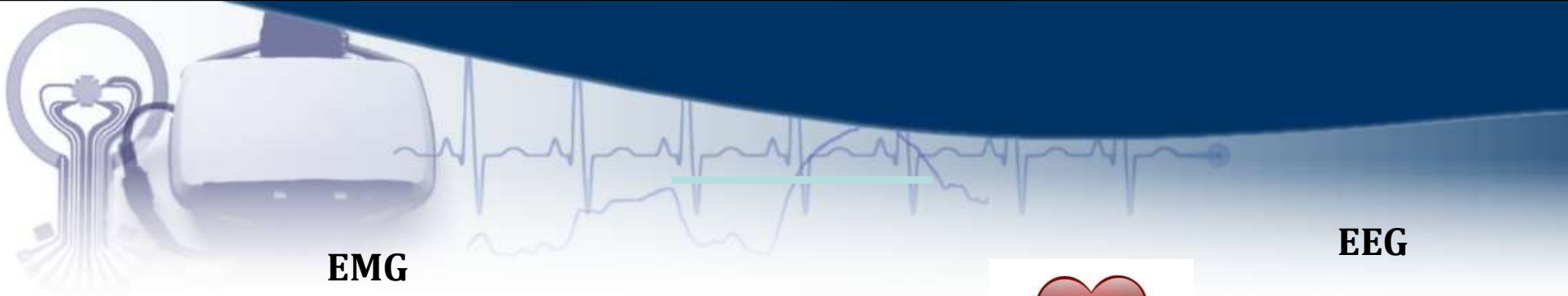

**EMG**

**EEG**

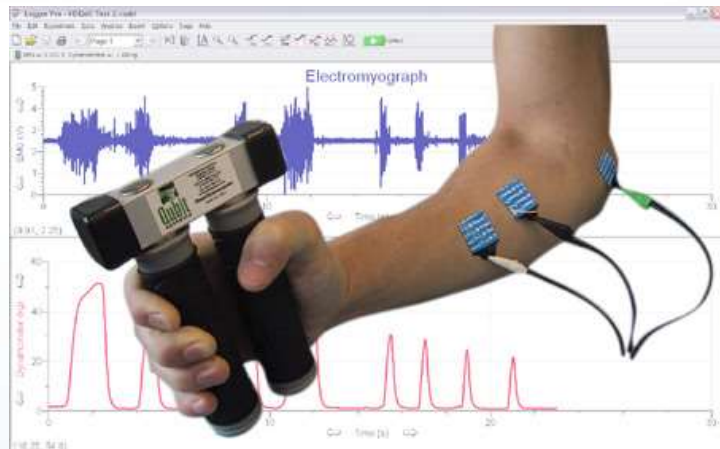

**ECG**



**GSR**

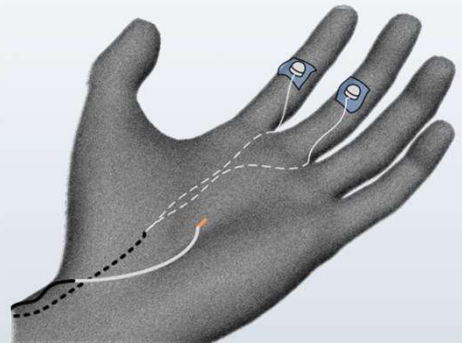

**EOG**



**Impédance**

Loi d'Ohm généralisée

$$U = Z * I$$

U en Volts

I en Ampères

Z en Ohm

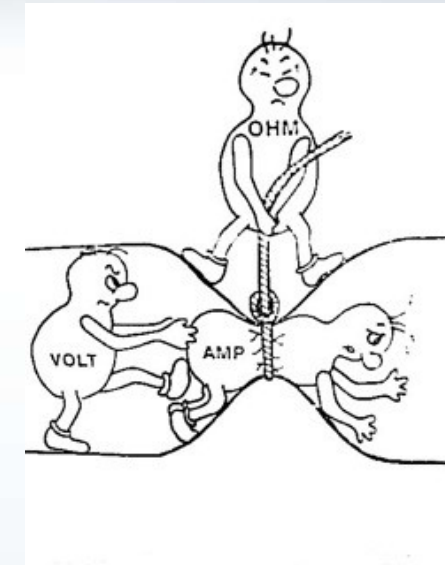

Impédance  $Z = \text{Résistance} + j * \text{Réactance}$

Rq: réactance uniquement capacitive sur le corps humain

# La cellule vivante

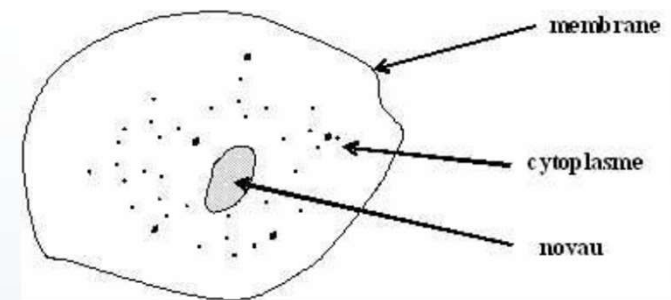
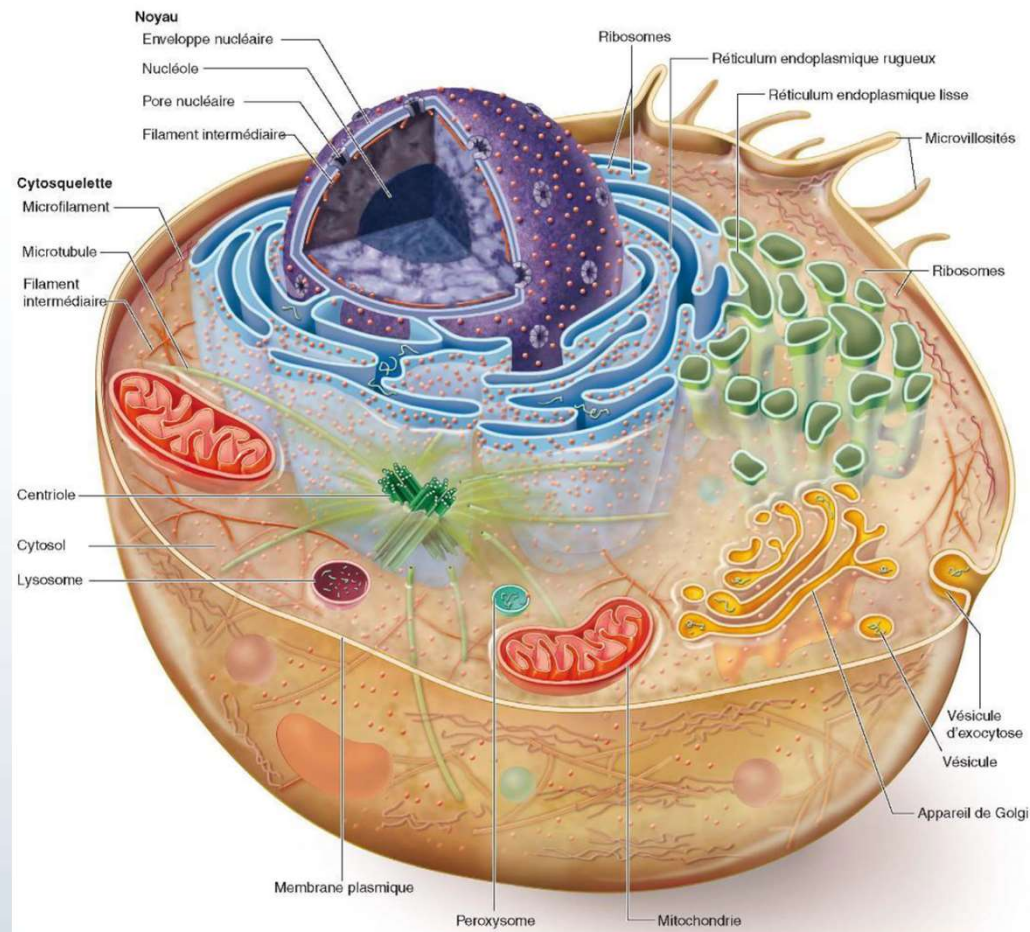

70 à 95% d'eau+ sels

## Compositions en Eau des tissus

Water Content Values for Various Tissues and Organs

TISSUE	WEIGHT %		TISSUE	WEIGHT %	
	WATER CONTENT			WATER CONTENT	
Bone	44–45		Lung	80–83	
Bone Marrow	8–16		Muscle	73–78	
Bowel	60–82		Ocular Tissues		
Brain			Choroid	78	
White matter	68–73		Cornea	75	
Grey matter	82–85		Iris	77	
Fat	5–20		Lens	65	
Kidney	78–79		Retina	89	
Liver	73–77		Skin	60–76	
			Spleen	76–81	

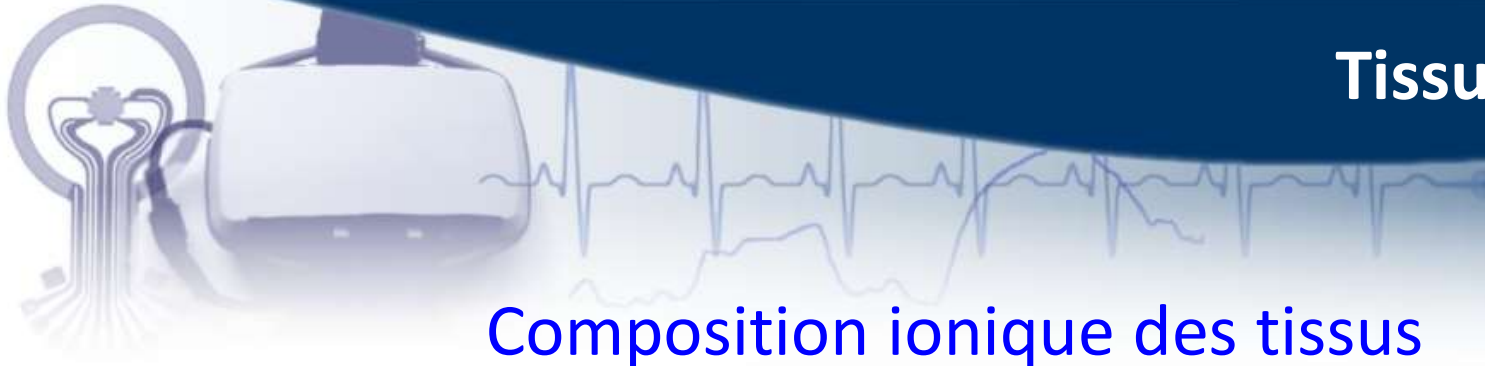

## Composition ionique des tissus

### Concentration of electrolytes in body liquids

	cations (meq/L)		anions (meq/L)		
	extracellular	intracellular	extracellular	intracellular	
Na <sup>+</sup>	142	10	Cl <sup>-</sup>	103	4
K <sup>+</sup>	4	140	HCO <sub>3</sub> <sup>-</sup>	24	10
Ca <sup>2+</sup>	5	10 <sup>-4</sup>	protein-	16	36
Mg <sup>2+</sup>	2	30	HPO <sub>4</sub> <sup>2-</sup> + SO <sub>4</sub> <sup>2-</sup>	10	130
H <sup>+</sup>	4×10 <sup>-5</sup>	4×10 <sup>-5</sup>	+ organic acids		
Sum	153	180	Sum	153	180

mEq = mmol\* valence

# Impédance du corps humain ?

## Composition du corps humain :

- Milieux conducteurs (de l'électricité) :
  - Nombreux électrolytes :  $\text{Na}^+$ ,  $\text{K}^+$ ,  $\text{Ca}^+$ ,  $\text{Cl}^-$ ...
  - –En milieu aqueux : sang, lymphe, milieu interstitiel, milieu intracellulaire...
- Milieux isolants (de l'électricité) :
  - –Membranes cellulaires (couches bi-lipidiques)
  - –Adipocytes (cellule réservoir de triglycérides)
  - –Matière minérale
  - –Air
  - –Couche cornée (stratum corneum)



# Electrisation des tissus biologiques

Effets du passage du courant alternatif (50 ou 60 Hz) sur le corps humain:

- de la simple sensation
- jusqu'à l'électrisation
- puis l'électrocution

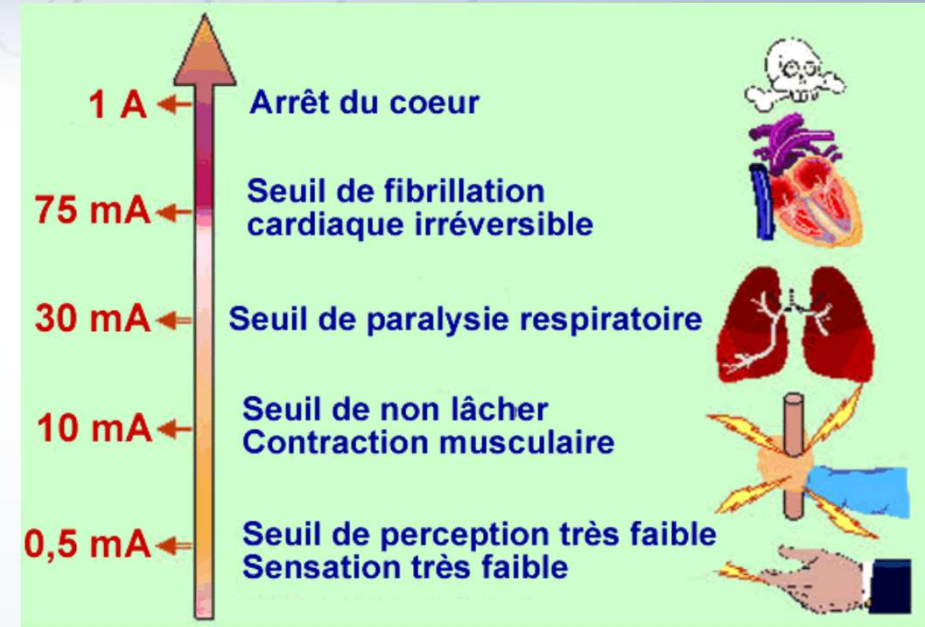
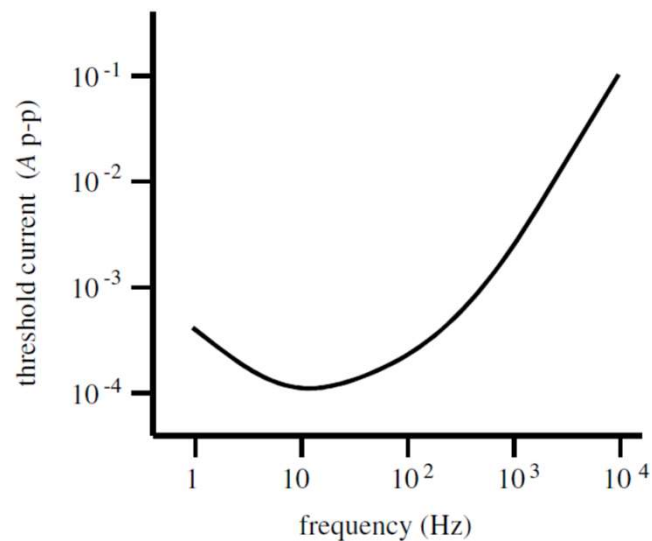

Seuil de sensation en fonction de  $f$  pour un courant appliqué entre des électrodes anneau de 5mm de large entourant 2 doigts adjacents (sujet sain)

- Courant  $I$  imposé sinusoïdal
- Tension  $V$  mesurée sinusoïdale
- Impédance

$$I = |I|e^{j(\omega t + \Phi_I)}$$

$$V = |V|e^{j(\omega t + \Phi_V)}$$

$$Z = \frac{V}{I}$$

- Module Impédance

$$|Z| = \frac{|V|}{|I|}$$

- Phase Impédance

$$\Phi_V = \Phi_I + \theta$$

- Résistance  $Z_R = R$  indépendante de la fréquence,  $\phi = 0$
- Condensateur  $Z_C = 1/j.C.\omega$ , diminue avec la fréquence,  $\phi = -90^\circ$

# Propriétés électriques des tissus biologiques

- $\sigma$ : conductivité ( $= 1/\rho$ )

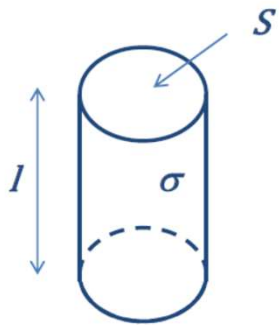

$$R = \rho \frac{l}{S} = \frac{l}{\sigma S}$$

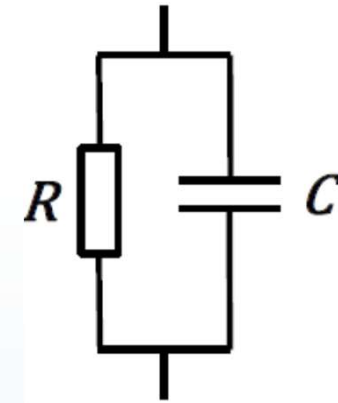

- $\epsilon_r$ : permittivité **diélectrique** relative

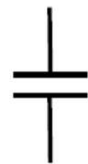
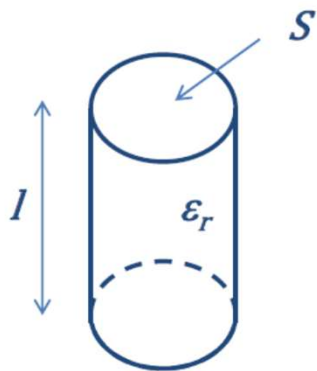

$$C = \frac{S}{l} \epsilon_0 \epsilon_r$$

$$Y = \frac{1}{Z} = \frac{1}{R} + jC\omega$$

$$= \frac{S}{l} (\sigma + j\omega \epsilon_0 \epsilon_r)$$

# Propriétés électriques des tissus biologiques

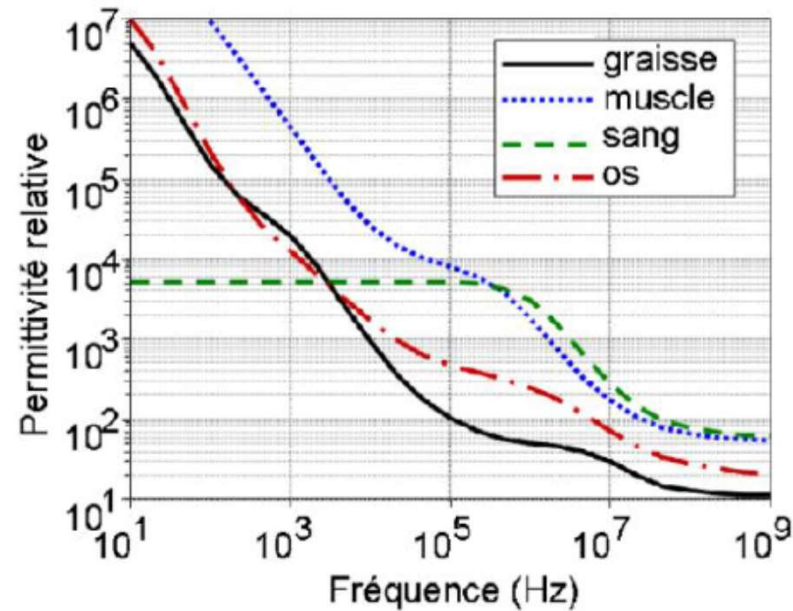
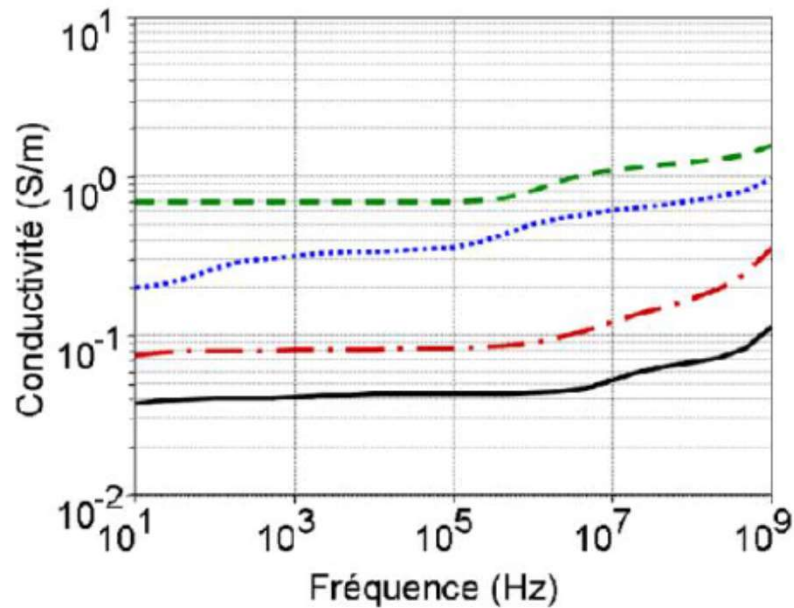

Gabriel et al. 1996

⇒ et lorsqu'un courant électrique va traverser tout cela ?!

- tissus : lieu, géométrie, proportions, orientations relatives (anisotropie)...
- fréquence du courant
- électrodes : matériau, rugosité, surface, écartement, agencement ...

# Propriétés électriques des tissus biologiques

Tissue	$\sigma$ [S/m] 1 Hz to 10 kHz	$\sigma$ [S/m] $\sim$ 1 MHz	$\Phi_{\max}$ at $<10$ MHz	Anisotropy
Human skin, dry	$10^{-7}$	$10^{-4}$	$80^\circ$	?
Human skin, wet	$10^{-5}$	$10^{-4}$	$30^\circ$	?
Bone	0.005–0.06		$20^\circ$	Strong
Fat	0.02–0.05	0.02–0.05	$3^\circ$	Small
Lung	0.05–0.4	0.1–0.6	$15^\circ$	Local
Brain (gray matter)	0.03–0.4	0.15	$15^\circ$	Small
Brain (white matter)	0.03–0.3			Strong
Liver	0.2	0.3	$5^\circ$	?
Muscle	0.05–0.4	0.6	$30^\circ$	Strong
Whole blood	0.7	0.7	$20^\circ$	Flow dependent
Urine	0.5–2.6	0.5–2.6	$0^\circ$	0
Cerebrospinal fluid (CSF)	1.6	1.6	$0^\circ$	0
Saline, 0.9%, 20 °C	1.3	1.3	$0^\circ$	0
Saline, 0.9%, 37 °C	2	2	$0^\circ$	0
Seawater	5	5	$0^\circ$	0

Paramètres physiologiques influençant la conductivité et la permittivité:

- État physiologique
- Taux d'hydratation
- Température
- âge

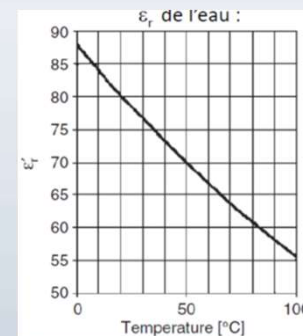

# Représentation graphique de l'impédance

Notation Cartésienne <-> polaire

$$Z = R + jX$$

$$Z = |Z|e^{j\arg(Z)}$$

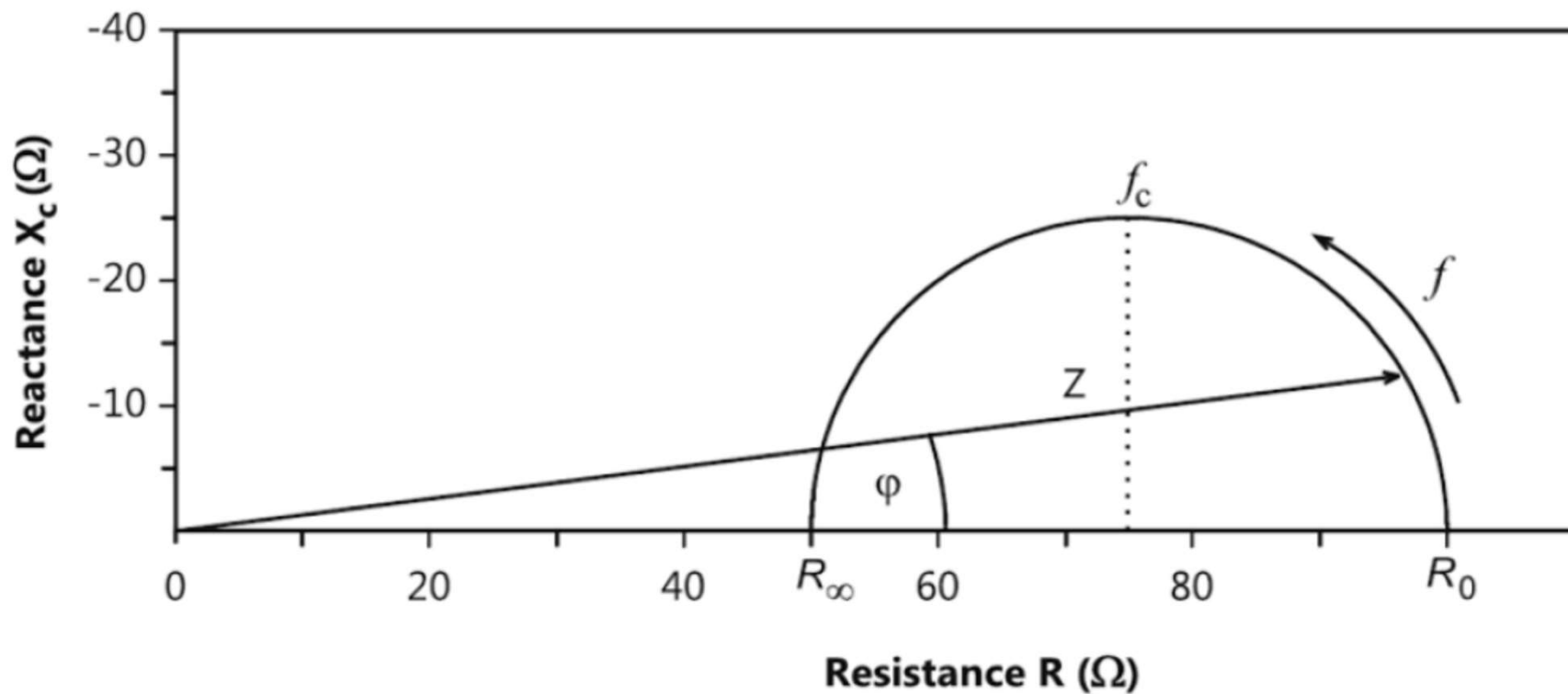

# Mesure de la Bioimpédance

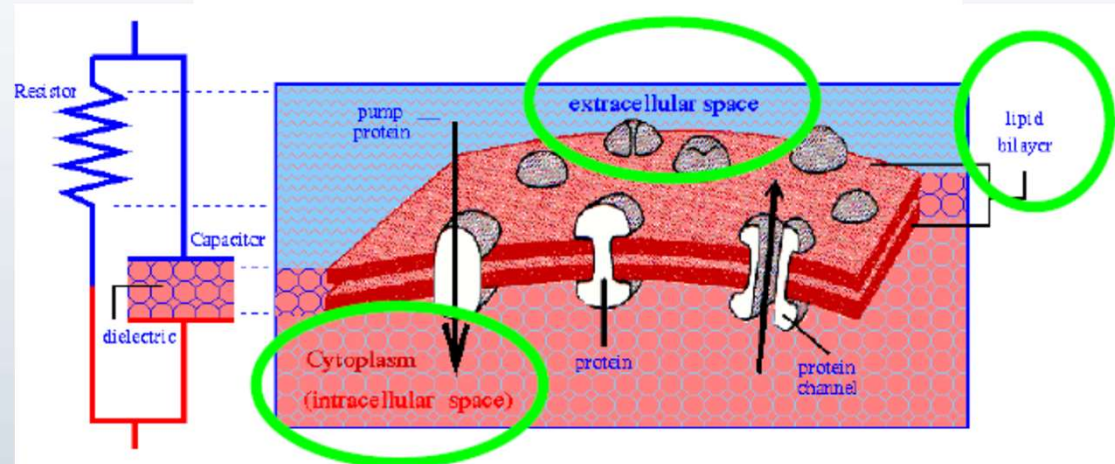
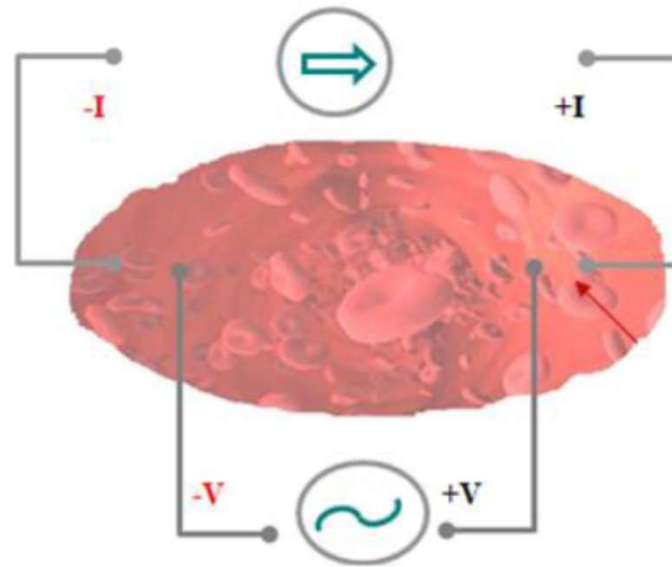

# Mesure à 2 électrodes

- À 2 électrodes :
  - I appliqué
  - V mesuré

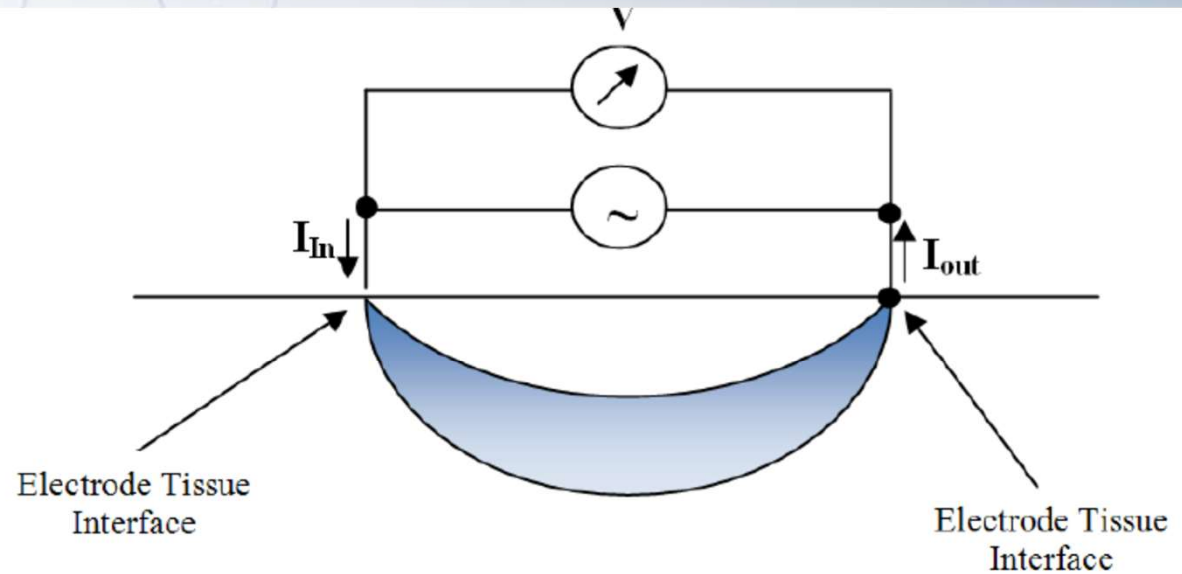

## 2 ELECTRODES

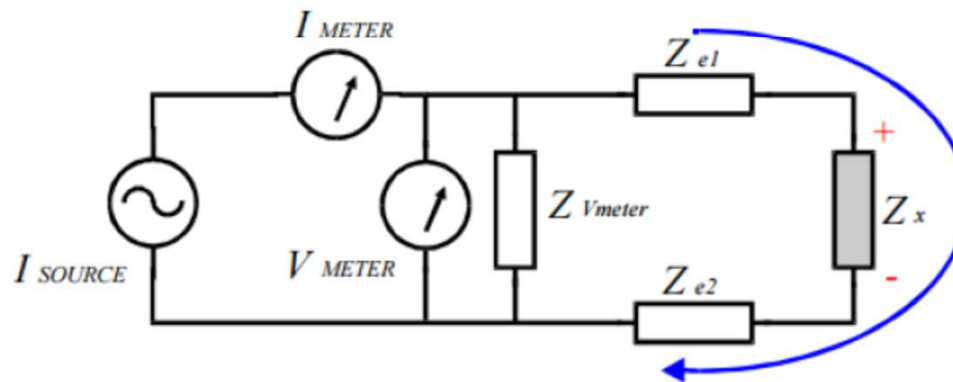

$$Z_{MEAS} = \frac{V_{MEAS}}{I_{MEAS}} = Z_x + Z_{e1} + Z_{e2} \approx \begin{cases} Z_{e1} + Z_{e2} \\ Z_e \gg Z_x \\ Z_{VMETER} \gg 2 \cdot Z_e \end{cases}$$



# Mesure à 3 électrodes

- À 3 électrodes :

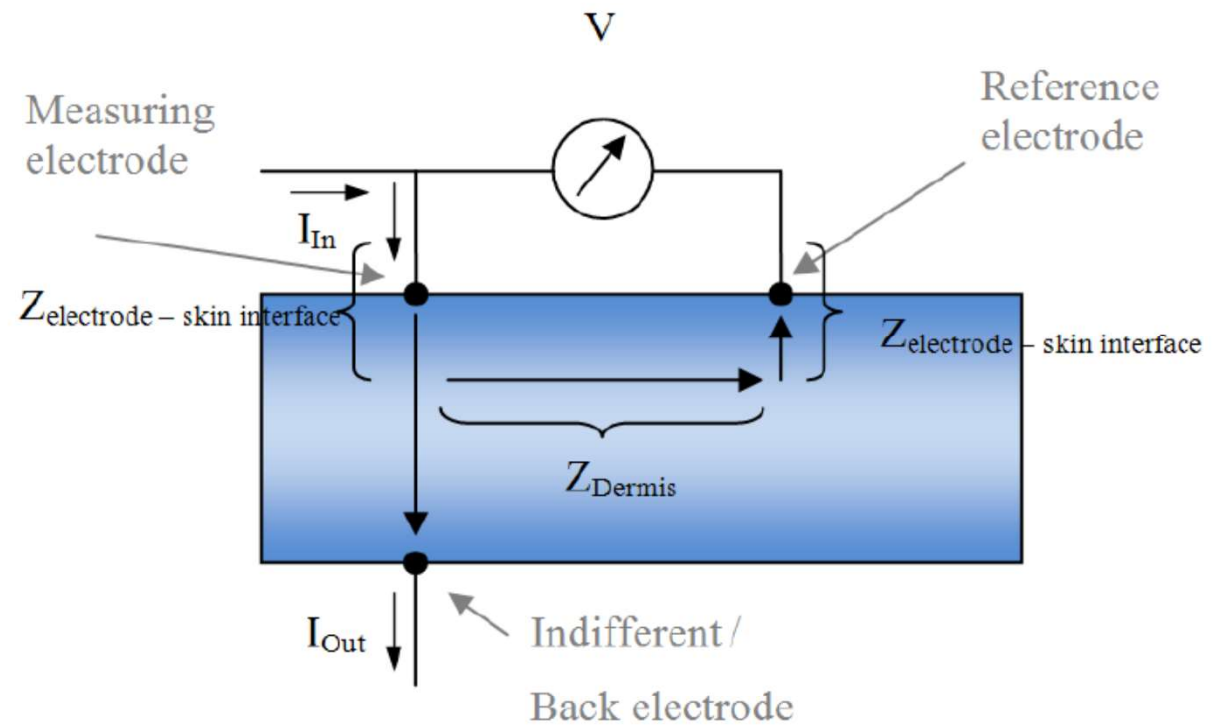

- Courant appliqué par 2 électrodes (measuring et back electrode)
- Une 3ème électrode est utilisée pour mesurer la tension résultante (ref)
- L'impédance mesurée est celle de l'électrode de mesure seule (et ses proches alentours) : mesure localisée.

# Mesure à 4 électrodes

- À 4 électrodes :
  - 1 paire injecte I
  - 1 paire mesure V

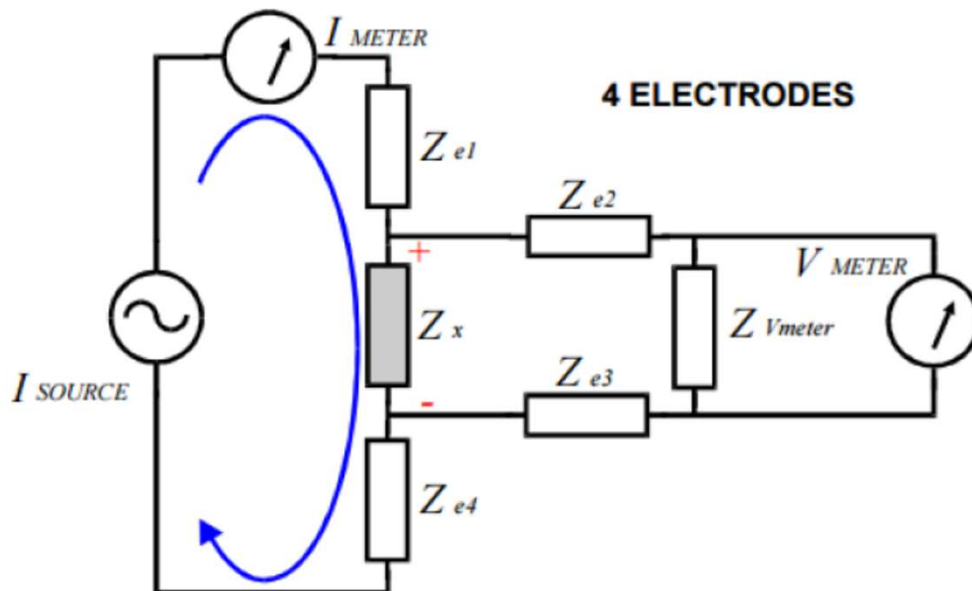
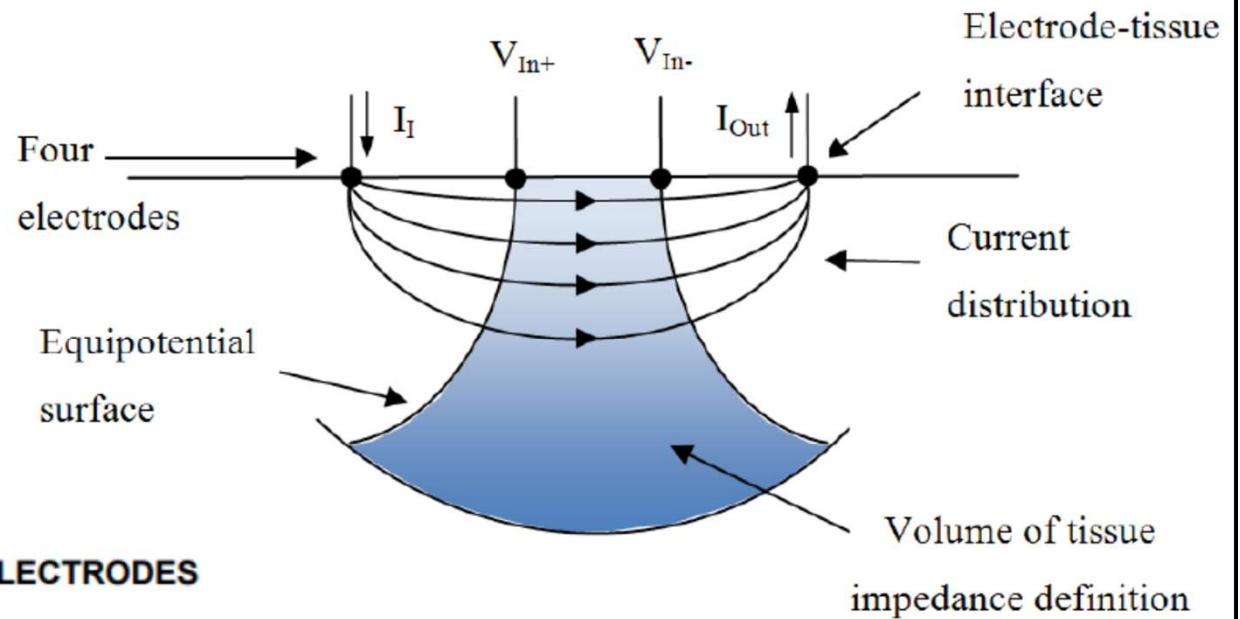

$$Z_{MEAS} = \frac{V_{MEAS}}{I_{MEAS}} = \left. \begin{array}{l} Z_x \\ Z_{VMETER} \gg Z_e \end{array} \right\}$$

- **Bioimpédance Fréquence unique (SFBIA)**
  - Analysis of bioimpedance information obtained at 50 KHz electric current is known as single-frequency bioimpedance analysis.
  - SFBIA is the most used and is one of the earliest proposed methods for the estimation of body compartments, it is based on the inverse proportion between assessed impedance and TBW, that represents the conductive path of the electric current
  - SFBIA predicts the volume of TBW that is composed of fluctuating percentages of ECF which is almost equal to 75% of TBW, and ICF that represent the rest
- **Bioimpédance Fréquence Multiple (MFBIA)**
  - Analysis of bioimpedance that is obtained at more than two frequencies is known as multiple-frequency bioimpedance analysis.
  - MFBIA is based on the finding that the ECF and TBW can be assessed by exposing it to low and high frequency electric currents, respectively
- **Sectrométrie de Bioimpédance (BIS)**

# Impédancemétrie Corps entier

## Principaux segments corporels

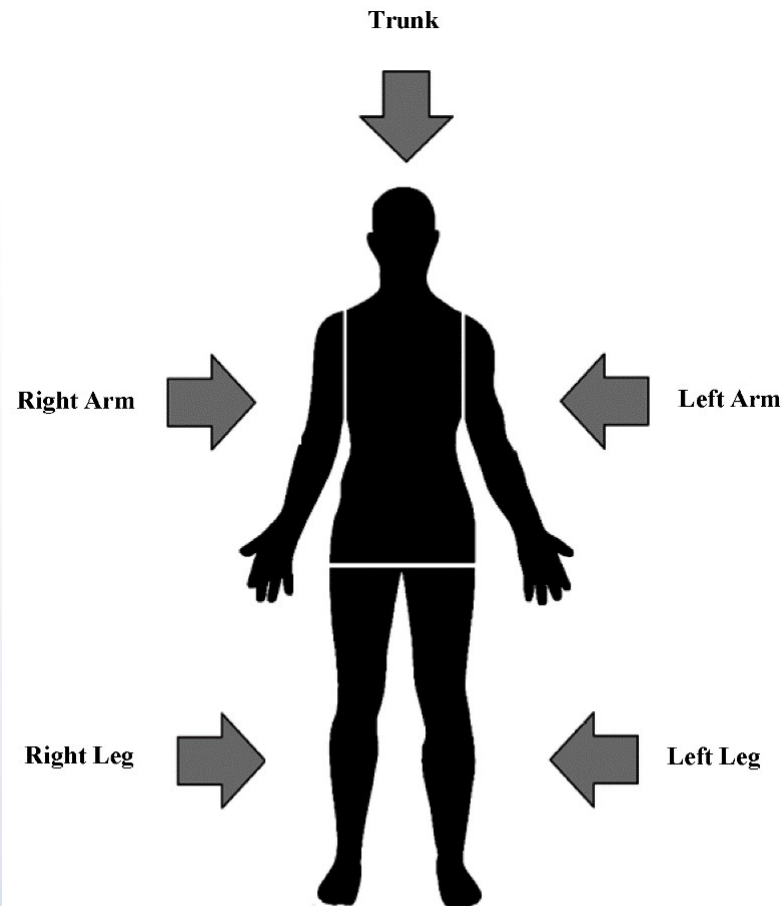

Fat Mass	Bone mass	Protein	Extracellular Fluids (29%)
Fat Free Mass	Body Cell Mass	Total Body Water (73%)	Intercellular Fluids (44%)

# Impédancemétrie corps entier

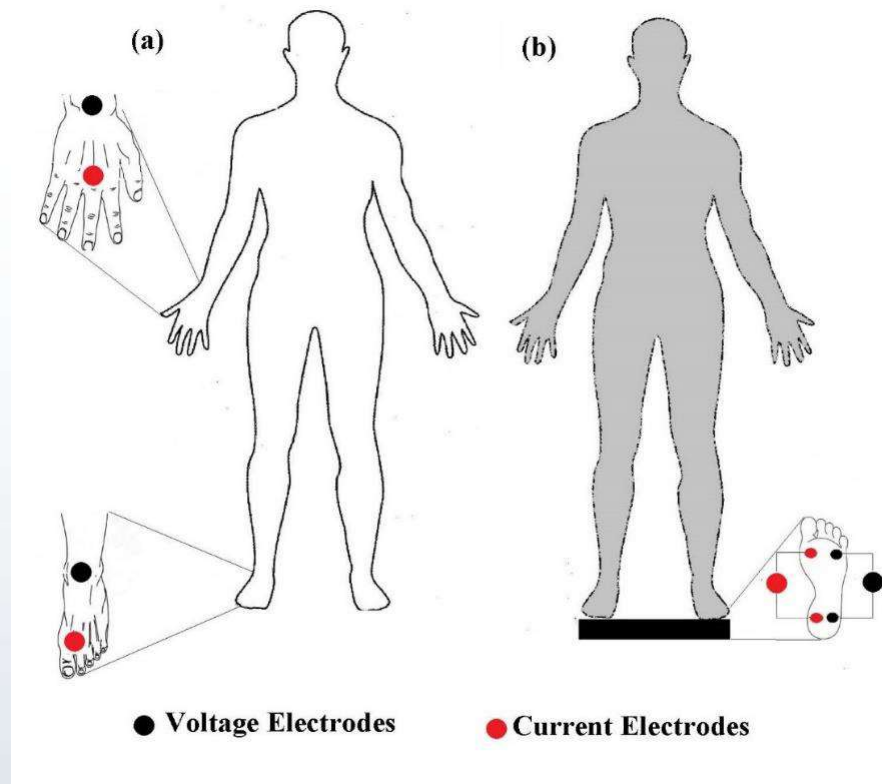

(a): Hand to Foot. (b): Foot to Foot

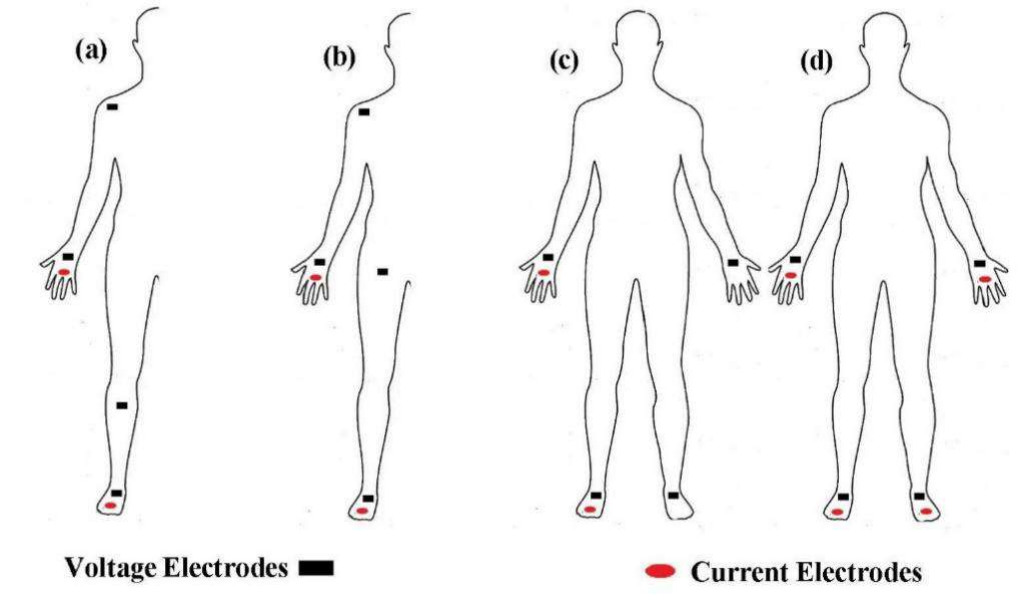

# Sectrométrie de Bioimpédance (BIS)

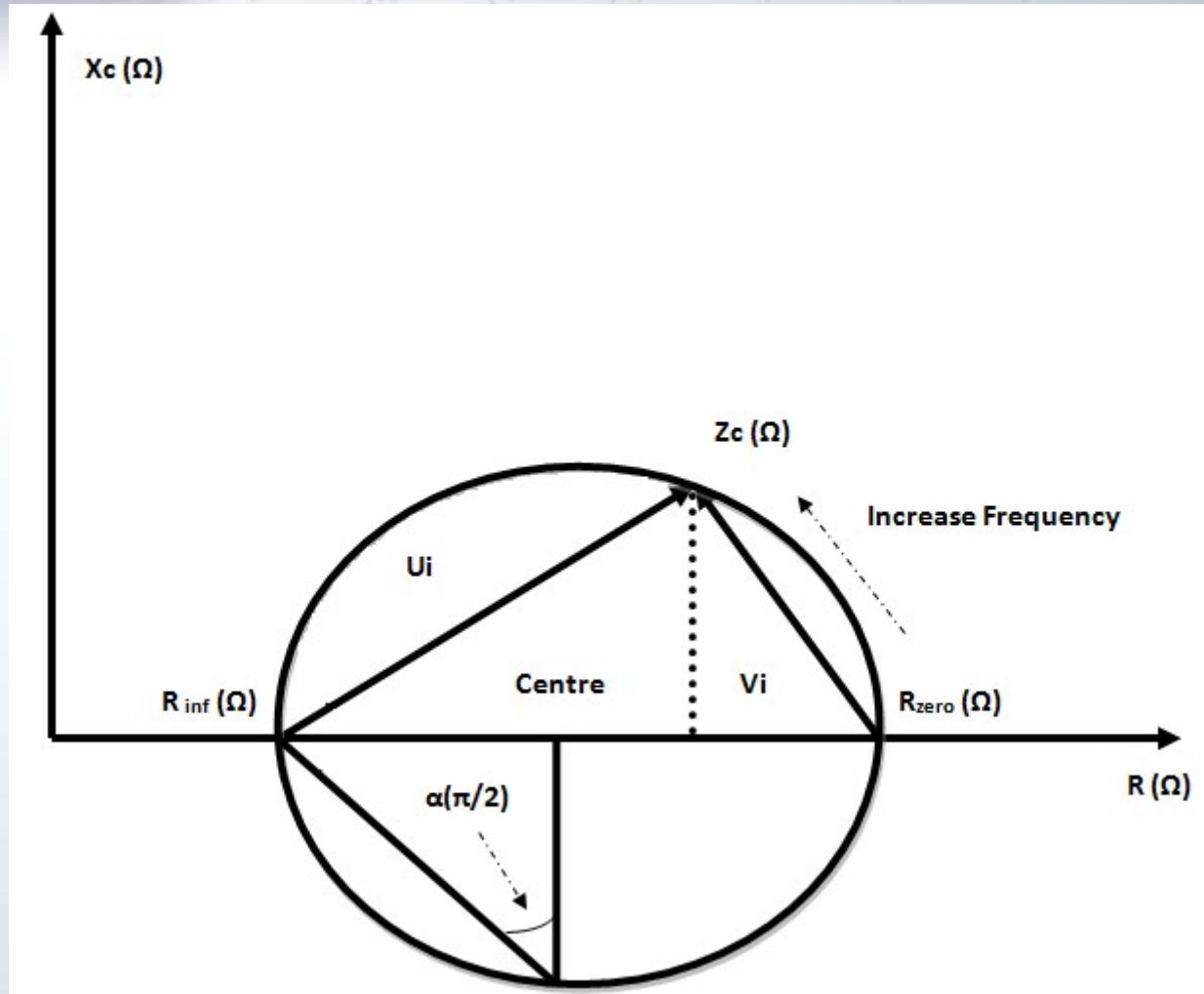

# Analyseur d'impédance pour la recherche



## Caractéristiques principales

- 1 mHz à 500 kHz, 1 m $\Omega$  à 1 T $\Omega$
  - 0,05% de précision de base
  - Compensation des parasites et indicateur de confiance
  - API de LabOne pour Python, C, MATLAB<sup>®</sup> et LabVIEW<sup>™</sup>
- 
- analyse de l'impédance des tissus,
  - croissance cellulaire,
  - recherche sur les aliments